

Continual Assessment 2 2016
SCIENCE
Primary 5

Name: _____

Total
Marks:

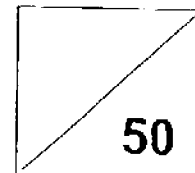

Class: Pr 5 _____

Register No. _____

Duration: 1h 15min

Date: 25 August 2016

Parent's Signature: _____

Instructions to Pupils:

1. Do not open the booklet until you are told to do so.
2. Follow all instructions carefully.
3. This paper consists of 2 sections, Part I and Part II.
4. For questions 1 to 14, shade your answers in the OAS provided.
5. For questions 15 to 21, write your answers in the spaces provided in Part II.

	Maximum	Marks Obtained
Part I	28 marks	
Part II	22 marks	
Total	50 marks	

* This booklet consists of 18 printed pages. (including the cover page)

This paper is not to be reproduced in part or whole without the permission of the Principal.

Practical Test		
	Maximum	Marks Obtained
Total	7 15 marks	

Part I (28 marks)

For each question from 1 to 14, four options are given. One of them is the correct answer. Make your choice (1, 2, 3 or 4). **Shade the correct oval (1, 2, 3 or 4) on the Optical Answer Sheet.**

1. Which of the following shows water losing heat as it changes from one state to another?

- A: A cube of ice melting.
- B: A puddle of rainwater drying up.
- C: Water droplets forming on the side of a glass.

- (1) A only
- (2) C only
- (3) B and C only
- (4) A, B and C

2. The diagram below shows the changes in the states of substance X.

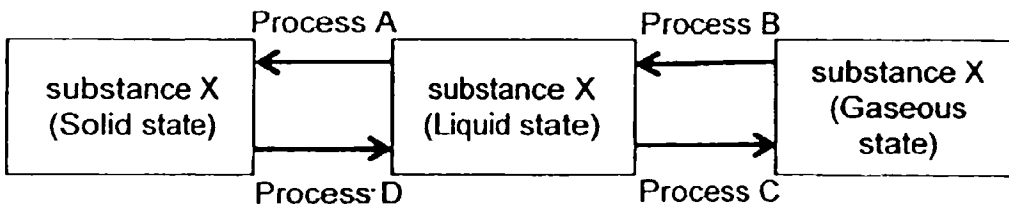

Which of the processes shown below is correct?

	A	B	C	D
(1)	freezing	condensation	melting	boiling
(2)	boiling	melting	freezing	condensation
(3)	boiling	freezing	condensation	melting
(4)	freezing	condensation	boiling	me

3. Study the diagram of the water cycle below.

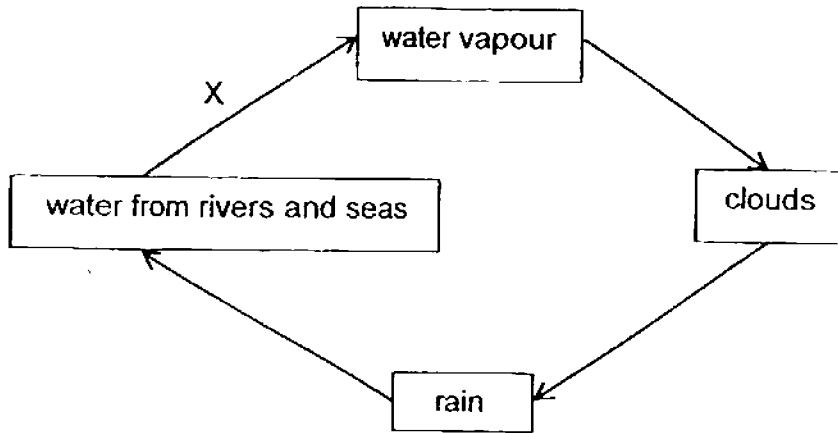

X represents one of the processes in the water cycle. Which of the following statements are true about process X?

- A: It occurs only at 100°C.
- B: It involves a change of state.
- C: It involves heat loss to the surrounding air.
- D: It involves heat gain by the water from rivers and seas.

- (1) A and C only
- (2) B and D only
- (3) C and D only
- (4) A, B and D only

4. Lisa used four beakers P, Q, R and S to investigate how the rate of evaporation of water was affected by the temperature of the water.

The table below shows the conditions of four different sets-ups at the start of the experiment. The four containers were placed at the same place.

	Set-up			
	P	Q	R	S
Volume of water in the container at first (cm ³)	300	300	350	400
Temperature of water (°C)	60	50	60	50

Which two set-ups should Lisa choose for her experiment to make it a fair test?

- (1) P and Q only
- (2) P and R only
- (3) Q and S only
- (4) R and S only

5. Mike heated a beaker of tap water and left the water to boil for 5 minutes. He then placed the beaker of water on the table for some time.

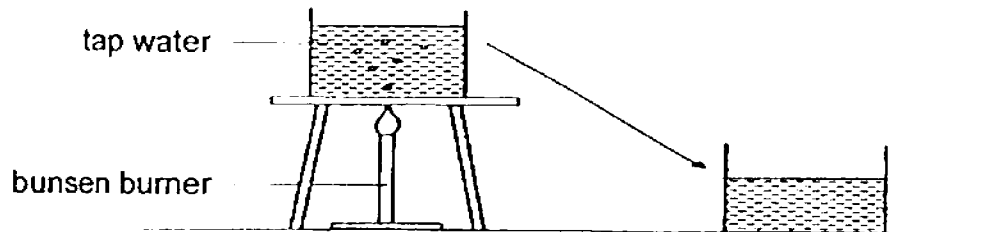

Which one of the graphs below best describes the changes in temperature of the water from the start till the end of the experiment?

- (1) Temperature ($^{\circ}\text{C}$)

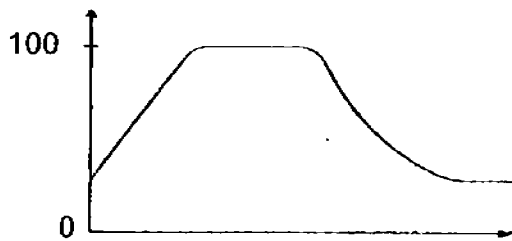

- (2) Temperature ($^{\circ}\text{C}$)

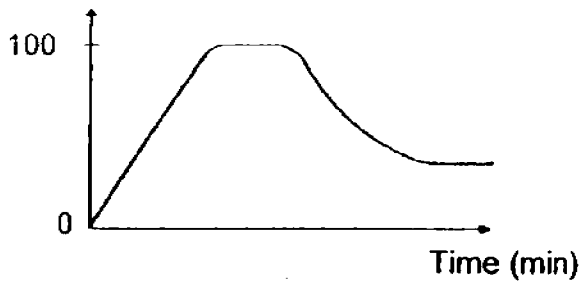

- (3) Temperature ($^{\circ}\text{C}$)

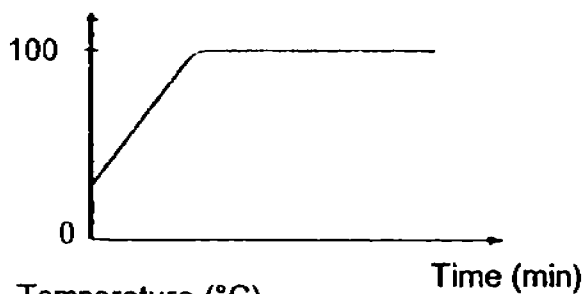

- (4) Temperature ($^{\circ}\text{C}$)

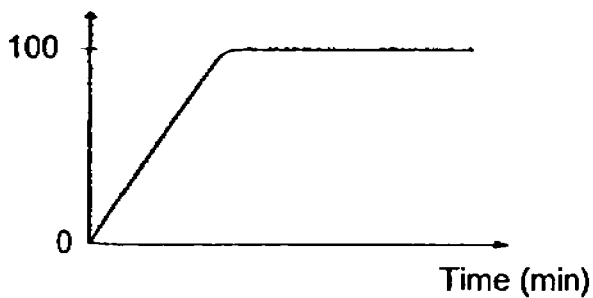

6. John poured water at different temperatures into 3 similar cups A, B and C and placed the cups on the table at room temperature. The diagram below showed how the cups looked like after 5 minutes.

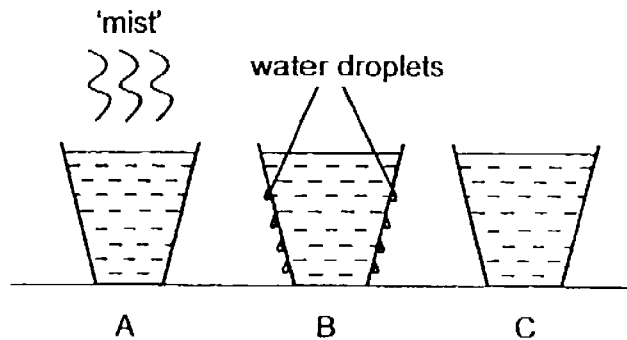

Arrange the cups according to the temperature of the water in the cups, from the highest temperature to the lowest temperature.

- (1) A, B, C
(2) A, C, B
(3) B, C, A
(4) C, B, A
7. Which of the following statement(s) about the female reproductive cell is/are true?

A: It has a nucleus.
B: It is fertilised by a sperm.
C: It is released from the ovary.

- (1) A only
(2) A and B only
(3) B and C only
(4) A, B and C

8. The diagram below shows the different parts of a flower.

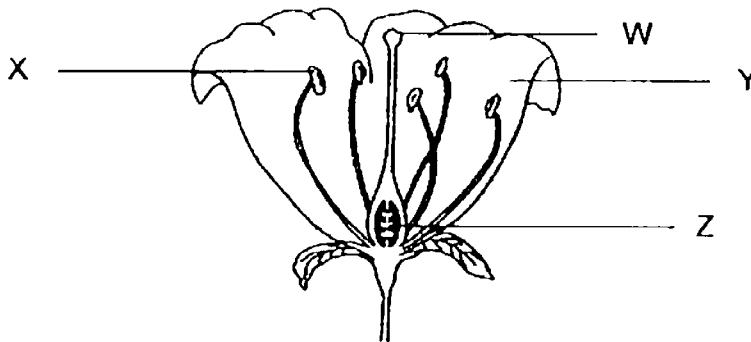

In which part of the flower does fertilisation take place?

- (1) W (2) X
 (3) Y (4) Z

9. The diagram below shows the life cycle of a flowering plant.

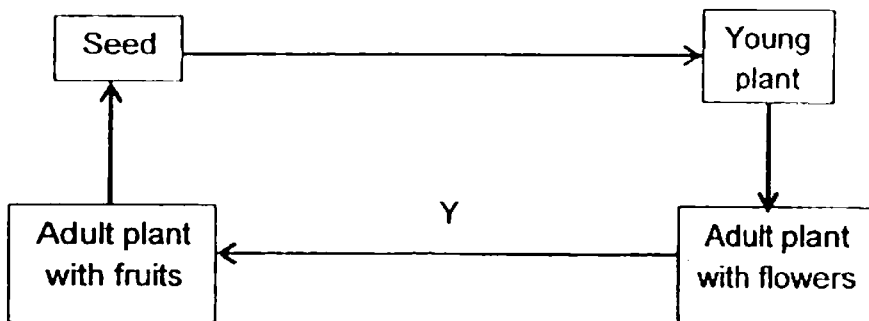

Which of the following process(es) is/are happening at Y?

- A: Pollination
 B: Fertilisation
 C: Germination

- (1) A only (2) B only
 (3) A and B only (4) A, B and C

10. Malcolm wanted to find out the effect of overcrowding on the germination of seeds of plant Y. He conducted an experiment and recorded his results in the table below.

Pot	Number of seeds of plant Y	Size of pot	Number of seeds germinated
X	12	medium	6
Y	12	big	10
Z	12	small	4

Based on the results above, what can Malcolm infer on the effect of the size of the pot on the number of seeds germinated?

- (1) The size of the pot does not affect the number of seeds germinated.
 - (2) The bigger the size of the pot, the more the number of seeds germinated.
 - (3) The bigger the size of the pot, the lesser the number of seeds germinated.
 - (4) The smaller the size of the pot, the more the number of seeds germinated.
11. Danny set-up an experiment as shown below.

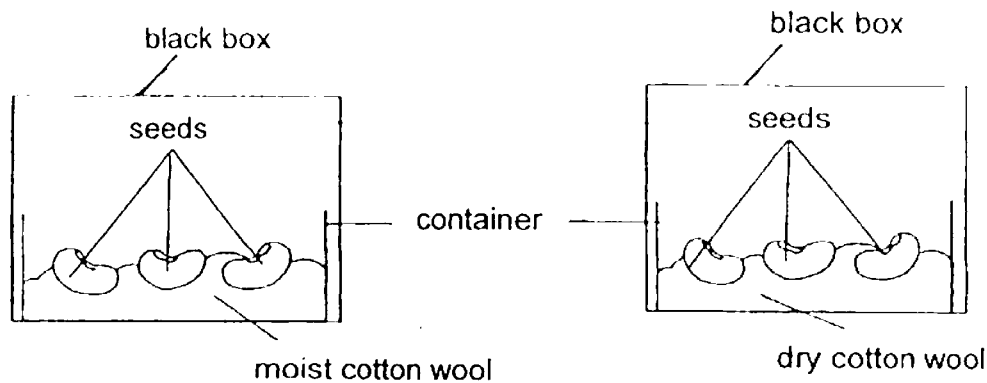

What is the aim for Danny's experiment?

- (1) To find out if air is needed for germination.
- (2) To find out if light is needed for germination.
- (3) To find out if water is needed for germination.
- (4) To find out if warmth is needed for germination.

12. Ravi carried out an experiment to find out if bees are attracted to water with sugar.

He used two similar plastic flowers of different colours and sprayed each of them with 5 ml of water with sugar as shown below.

The plastic flowers were left in an open garden for five hours. The number of bees visiting each flower was counted.

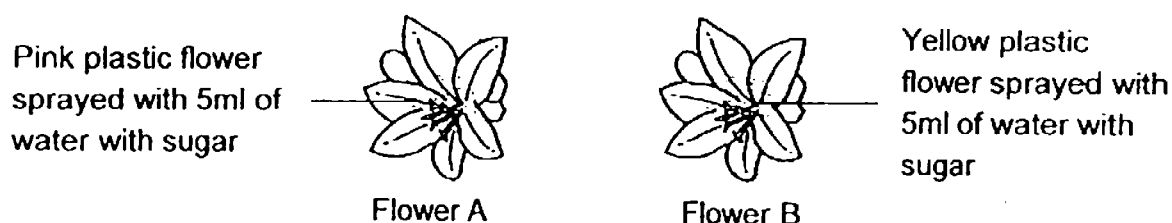

However, his teacher, Mrs Tan, told him that his experiment was not a fair one.

Which of the following changes must Ravi make for the experiment to be a fair one?

- A: The colour of the flower should be made the same.
- B: The water with sugar should only be sprayed on one flower.
- C: More water with sugar should be sprayed on one of the flowers.

- (1) A and B only
- (3) B and C only

- (2) A and C only
- (4) A, B and C

13. Study the flowchart below.

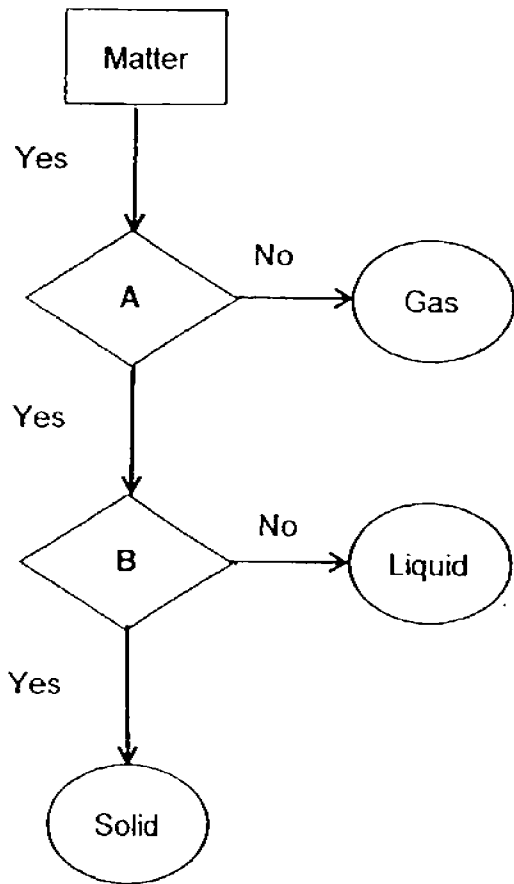

Which of this following questions are likely to represent A and B?

	A	B
(1)	Does it have fixed shape?	Does it have fixed volume?
(2)	Does it have fixed volume?	Does it have fixed shape?
(3)	Does it have fixed mass?	Does it have fixed shape?
(4)	Does it have fixed volume?	Does it have fixed mass?

Part II (22 marks)

For questions 15 and 21, write your answers in the space provided.

15. Sandy filled four identical containers A, B, C and D with 250ml of water. The containers were then left in four places with different weather conditions for six hours as shown in the table below.

Container	A	B	C	D
Conditions	Cloudy	Sunny	Sunny	Cloudy
	Windy	Not windy	Windy	Not windy

- (a) In the graph below, complete bars C and D to show the volume of water left in containers C and D after six hours. Bars A and B have been drawn for you.

[2]

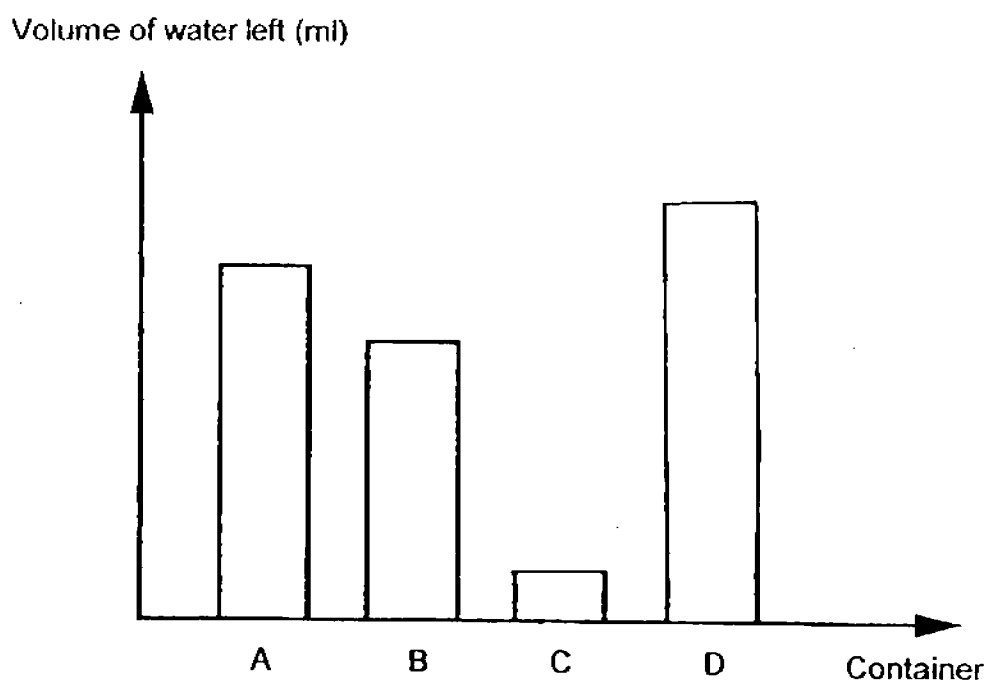

- (b) What conclusion can Sandy make from the experiment?

[1]

16. Anthony conducted an experiment to obtain water by using the set-up as shown below.

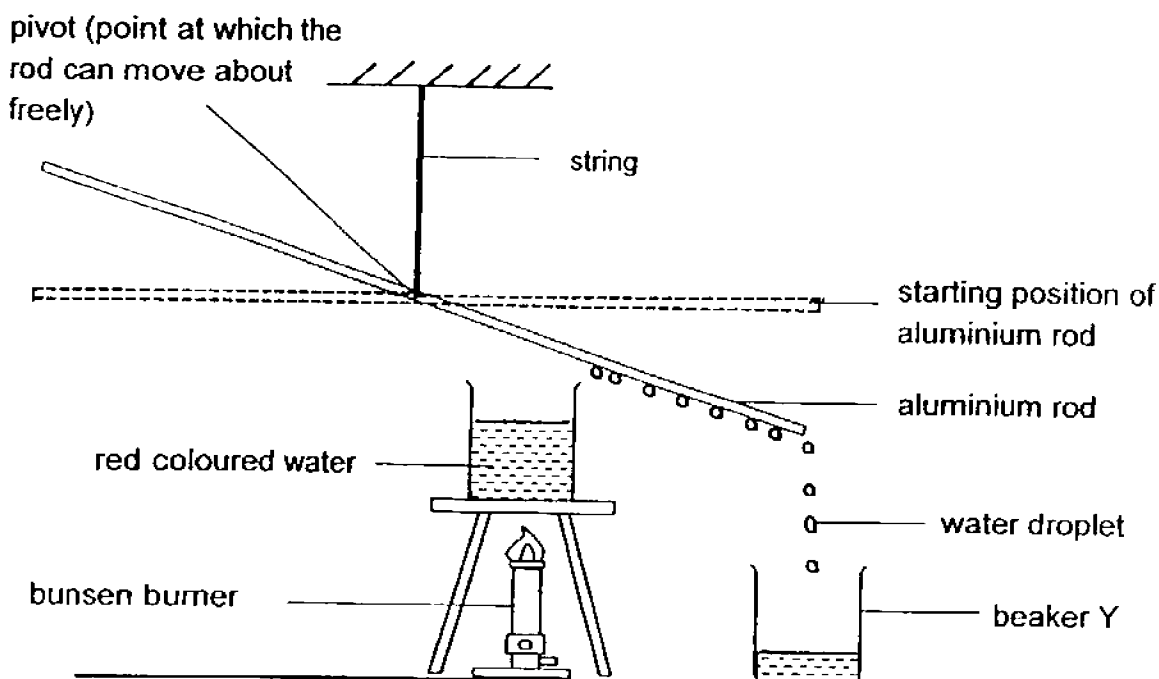

- (a) What will be the colour of the water collected in beaker Y? [1]

- (b) Explain why the aluminium rod tilted downwards? [2]

- (c) Without changing the set-up, suggest one way that Anthony can increase the amount of water collected in beaker Y. [1]

17. Randy prepared two set-ups A and B for his investigation. He put 5 seeds in set-up A and left both set-ups in a warm and dark place for 2 days.

He observed that the seeds in set-up A germinated and the limewater turned chalky in the presence of carbon dioxide. The limewater in set-up B remained clear.

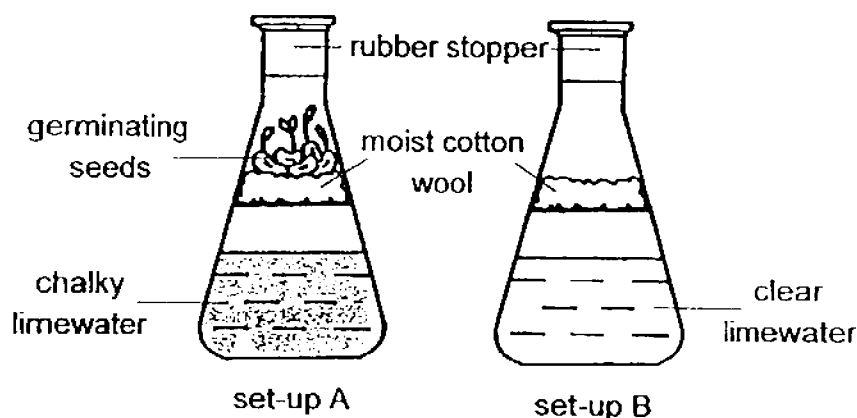

- (a) What can Randy conclude based on his observations from the set-ups above? [1]

- (b) What is the purpose of set-up B? [1]

Randy then conducted another experiment to investigate the effect of the temperature of the surrounding air on the number of days it takes for the seeds to germinate. He recorded his results in the table below.

Set-up	Temperature of the surrounding air (°C)
C	24
D	35
E	28

- (c) What would he measure for his experiment? [1]

Question 17 continues on page 13

- (d) He used the same type of seeds for his experiment. Explain why this is important. [1]

- (e) Other than warmth, name one other factor needed for seeds to germinate. [1]

18. The diagram below shows flower A with both male and female parts.

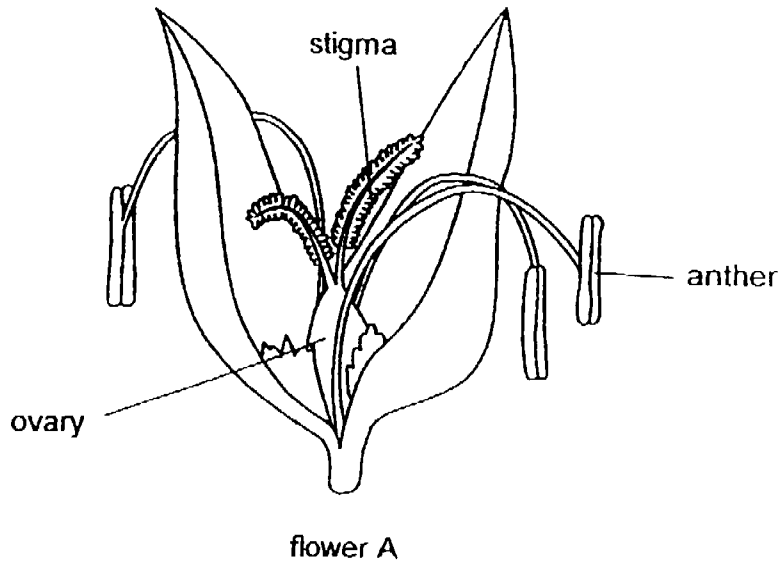

- (a) If the anther was removed from flower A, would the flower still be able to undergo the process of fertilisation? Explain your answer. [1]

- (b) What would happen to the ovary after the process of fertilisation? [1]

19. The diagrams below show the life cycles of animal X and Y.

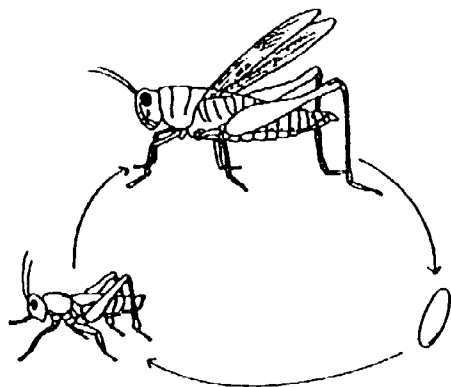

Life cycle of animal X

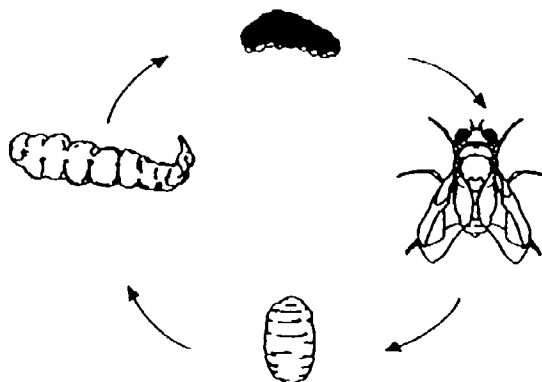

Life cycle of animal Y

Based on the diagrams above, state one similarity and one difference between the life cycles of animal X and Y.

[2]

(a) Similarity: _____

(b) Difference: _____

20. Irman filled two similar syringes, X and Y, with the same volume of water and air as shown below. He covered each syringe with one finger.

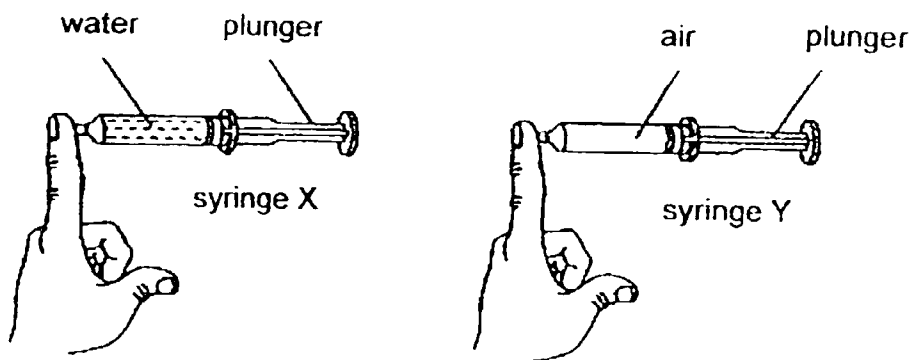

- (a) Which of the syringes (X or Y) would Irman be able to push the plunger in? Explain your choice. [2]

- (b) What property of water can Irman infer from the above experiment? [1]

21. Brenda set up the experiment below. She put blocks of ice into containers A, B and C and covered them using plastic lids. The containers were made from different materials. The containers were then placed in the same room.

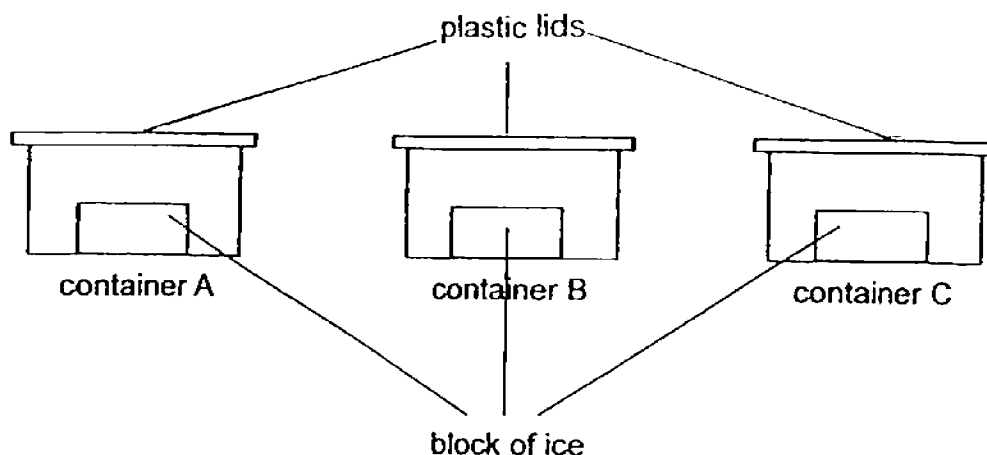

After 30 minutes, she measured the amount of water collected in each container. She recorded her findings below.

Container	Amount of water collected (ml)
A	20
B	35
C	40

- (a) Name one other variable that Brenda must keep the same in order to ensure that her experiment is a fair one. [1]

- (b) Which of these containers (A, B or C) would be the most suitable for making an ice cream container to prevent the ice cream from melting? Explain your choice. [2]

End of Paper

YEAR : 2016
LEVEL : PRIMARY 5
SCHOOL : ROSYTH
SUBJECT : SCIENCE
TERM : CA2

PART I

Q1	2	Q3	2	Q5	1	Q7	4	Q9	3	Q11	3	Q13	2
Q2	4	Q4	1	Q6	2	Q8	4	Q10	2	Q12	1	Q14	4

PART II

Q15a

Volume of water left (ml)

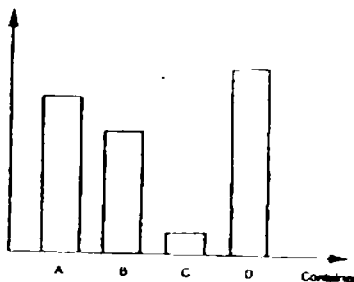

- Q15b** The more sunlight and wind, the lesser the volume of water left.
Q16a Colourless
Q16b Since there are water droplets on one side of the rod and water has mass.
Q16c Increase the amount of heat.
Q17a As the germinating seeds increase, carbon dioxide increases.
Q17b To confirm that germinating seeds are the only variable that affects the presence of carbon dioxide.
Q17c Number of days it takes for the seeds to germinate.
Q17d The different seeds have different rate of germination.
Q17e Water

- Q18a** **Yes, the stigma will still receive the pollen grains from the wind, as this is a wind-pollinated plant.**
- Q18b** **The ovary will become a fruit.**
- Q19a** **Similarity: Both life cycle starts with an egg.**
- Q19b** **Difference: Animal X's life cycle has 3 stages but animal Y's life cycle has 4 stages.**
- Q20a** **Syringe Y as it contains air which can be compressed.**
- Q20b** **Water has a definite volume.**
- Q21a** **Amount of water collected.**
- Q21b** **A, it is the poorest conductor of heat as the amount of water collected is the least amount.**

End